

FRENCH FITNESS

FFN-PLP / FFM-PLP

FRENCH FITNESS NAPA / MARIN
PULLOVER PLATE LOADED (NEW)

ASSEMBLY MANUAL



OR



FEATURES

- 11 gauge steel
- High quality steel tube ASTM A36 with 50 x 80 x 3mm
- Tungsten Inert Gas (TIG) welding
- Quality PU leather
- Electrostatic powder coating

TECH SPECS

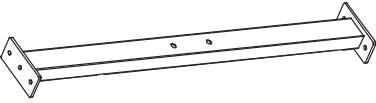
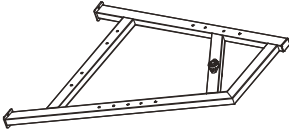
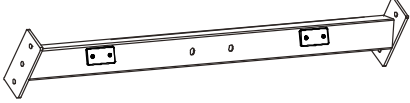
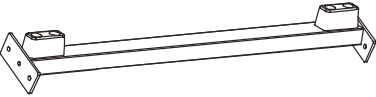
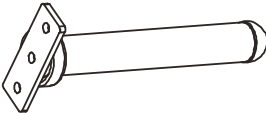
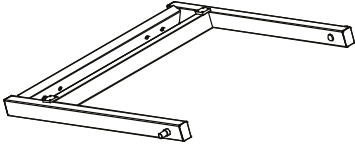
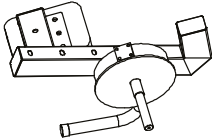
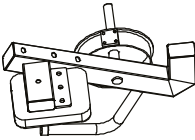
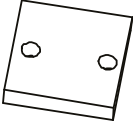

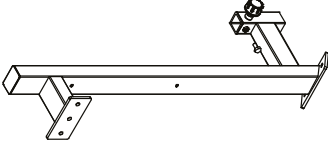
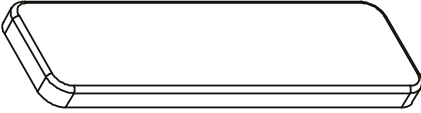
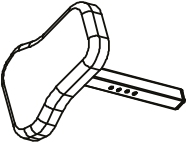
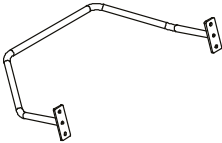
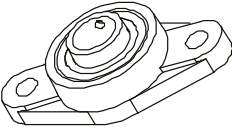
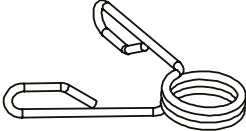

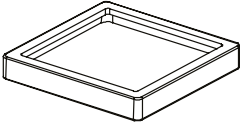
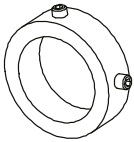
- Weight: 352 lb (160 kg)
- Dimensions: 55"L x 52"W x 59"H (L:1380mm, W:1300mm, H:1500mm)
- User Height Range: 4'11" to 6'5" (149.86 cm to 195.58 cm)

- **10 Years Parts, 1 Year Labor (Commercial)**
- **California Residents see Prop 65 WARNING**

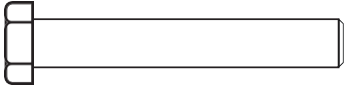
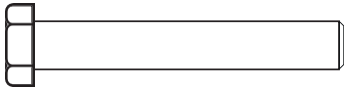
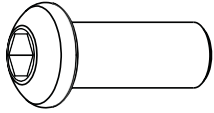
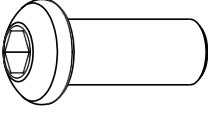
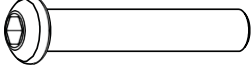

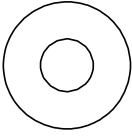
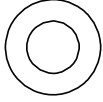

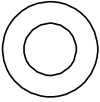
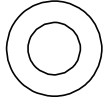
TABLE OF CONTENTS

PARTS LIST	4
BLISTER PACKAGE LIST	5
ASSEMBLY STEPS	6

PARTS LIST

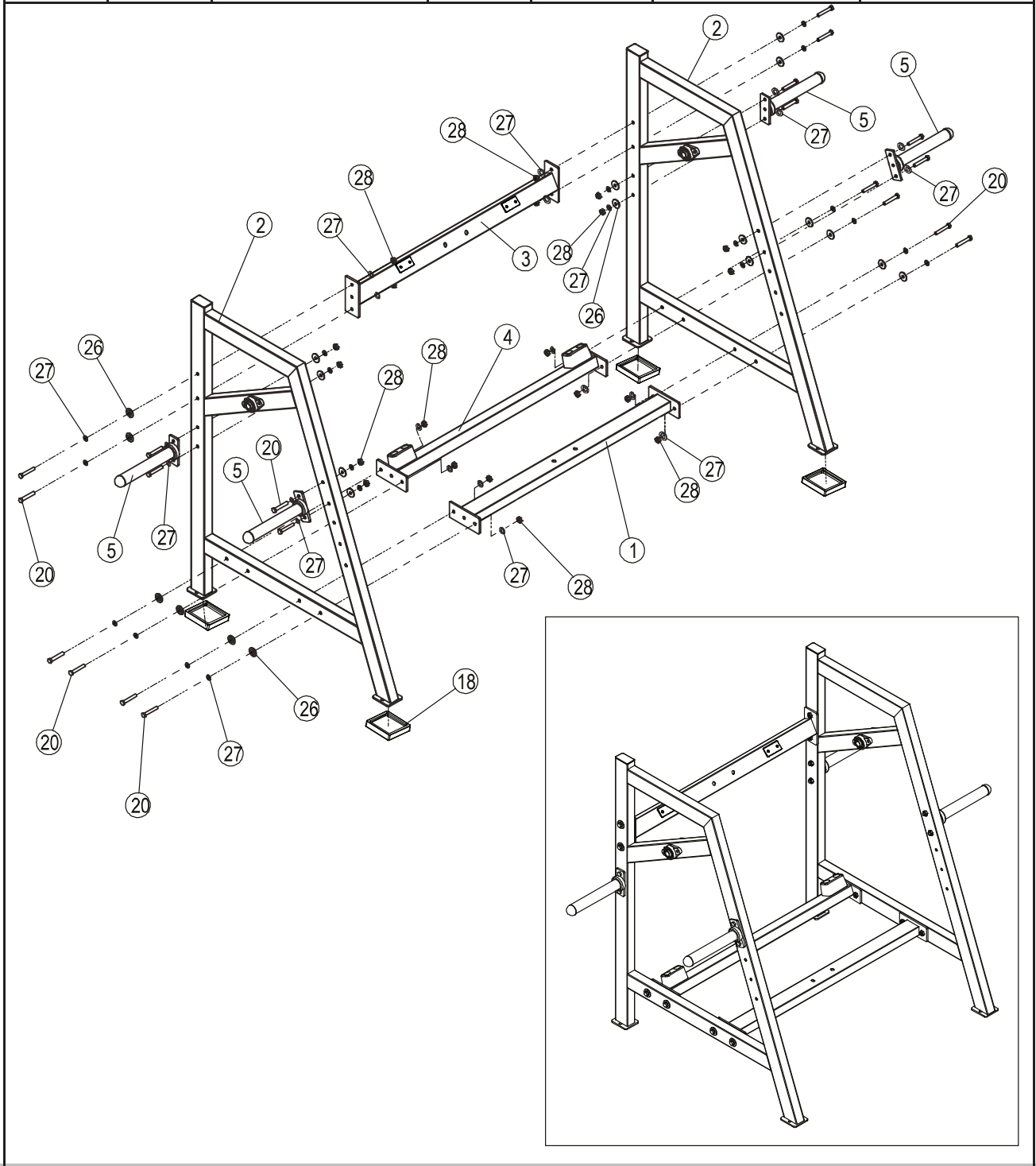
					
No.1	Main frame connector * 1	No.2	Main frame * 2	No.3	Rear support * 1
					
No.4	Bottom support * 1	No.5	Olympian tube * 6	No.6	Barbell plate rack * 1
					
No.7	Rotating arm right * 1	No.8	Rotating arm left * 1	No.9	Belt fixing plate * 4
					
No.10	Gravity belt * 2	No.11	Pad fixing bracket * 1	No.12	Back pad * 1
					
No.13	seat pad * 1	No.14	Arm support * 1	No.15	Bearing seat * 2
					
No.16	Spring collar 2" * 2	No.17	Bearing cover * 2	No.18	Rubber pad * 4
					
No.19	Limit collar * 2				

BLISTER PACKAGE LIST

					
No.20	M12*75 Hex bolt * 28	No.21	M12*80 Hex bolt * 4	No.22	M10*20 Allen inner hex bolt * 2
					
No.23	M8*20 Allen inner hex bolt * 9	No.24	M8*70 Allen inner Hex bolt * 2	No.25	M12*100 Hex bolt * 4
					
No.26	M12 Nylon washer * 36	No.27	M12 Flat washer * 72	No.28	M12 Nylon nut * 36
					
No.29	M8 Flat washer * 10	No.30	M10 Flat washer * 2		

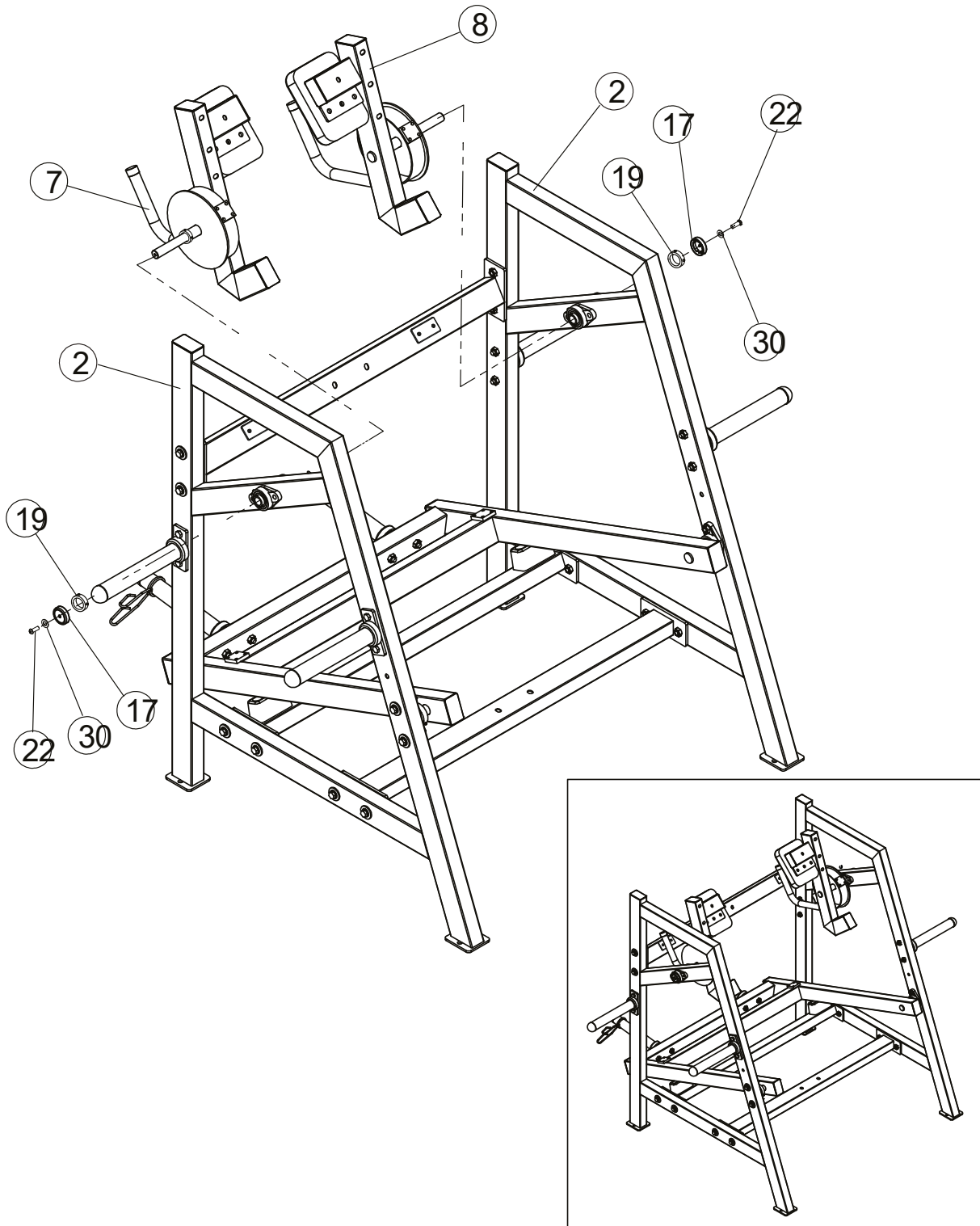
ASSEMBLY STEPS

Step NO.	Item NO.	Name	Quantity	Item NO.	Name	Quantity
1	No.1	Barbell plate rack	1	No.18	Rubber pad	4
	No.2	Main frame	2	No.20	M12*75 Hex bolt	20
	No.3	Rear support	1	No.26	M12 Nylon washer	20
	No.4	Bottom support	1	No.27	M12 Flat washer	40
	No.5	Olympian tube	4	No.28	M12 Nylon nut	20

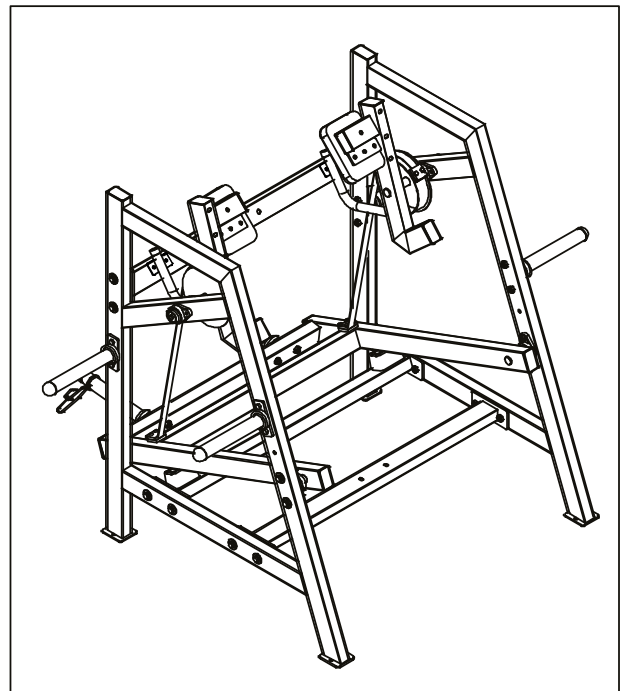
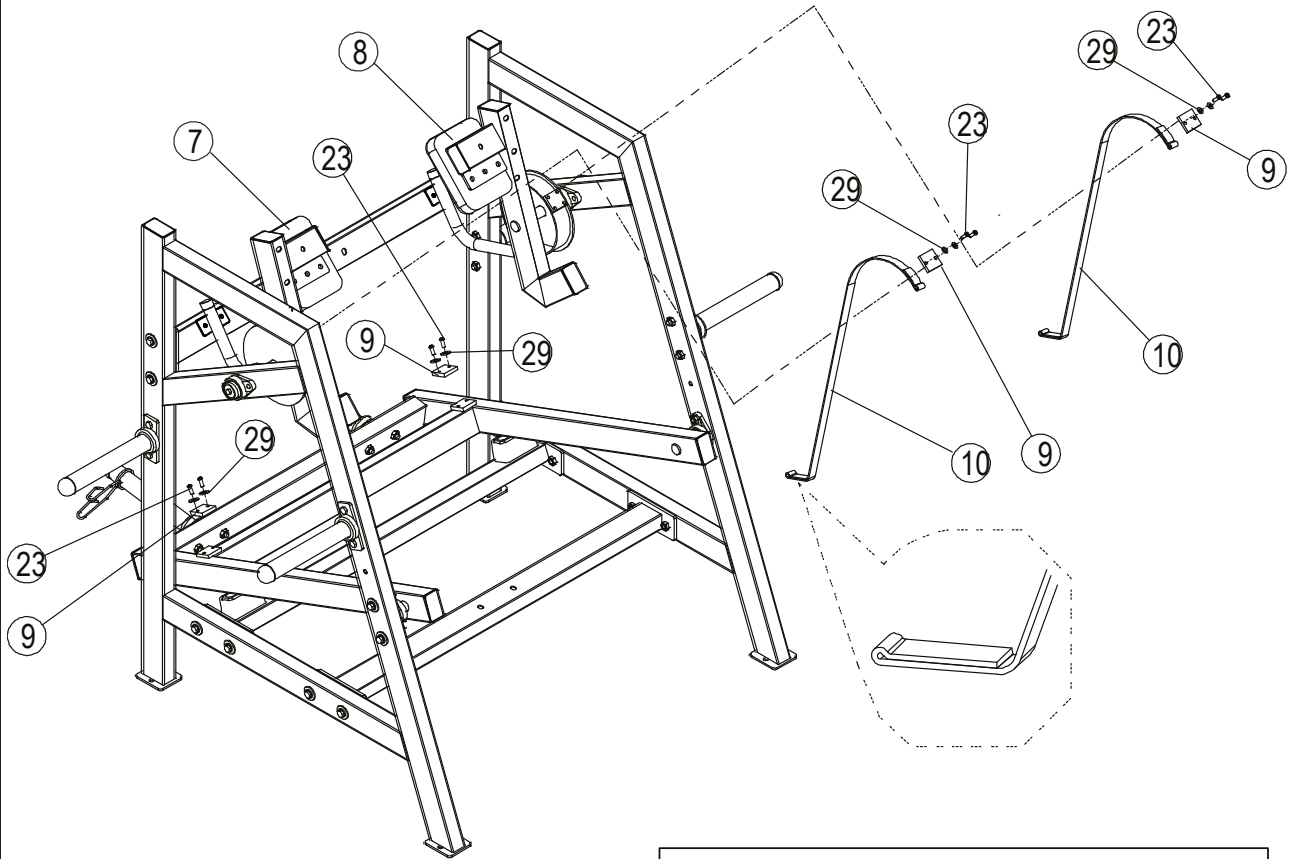


ASSEMBLY STEPS

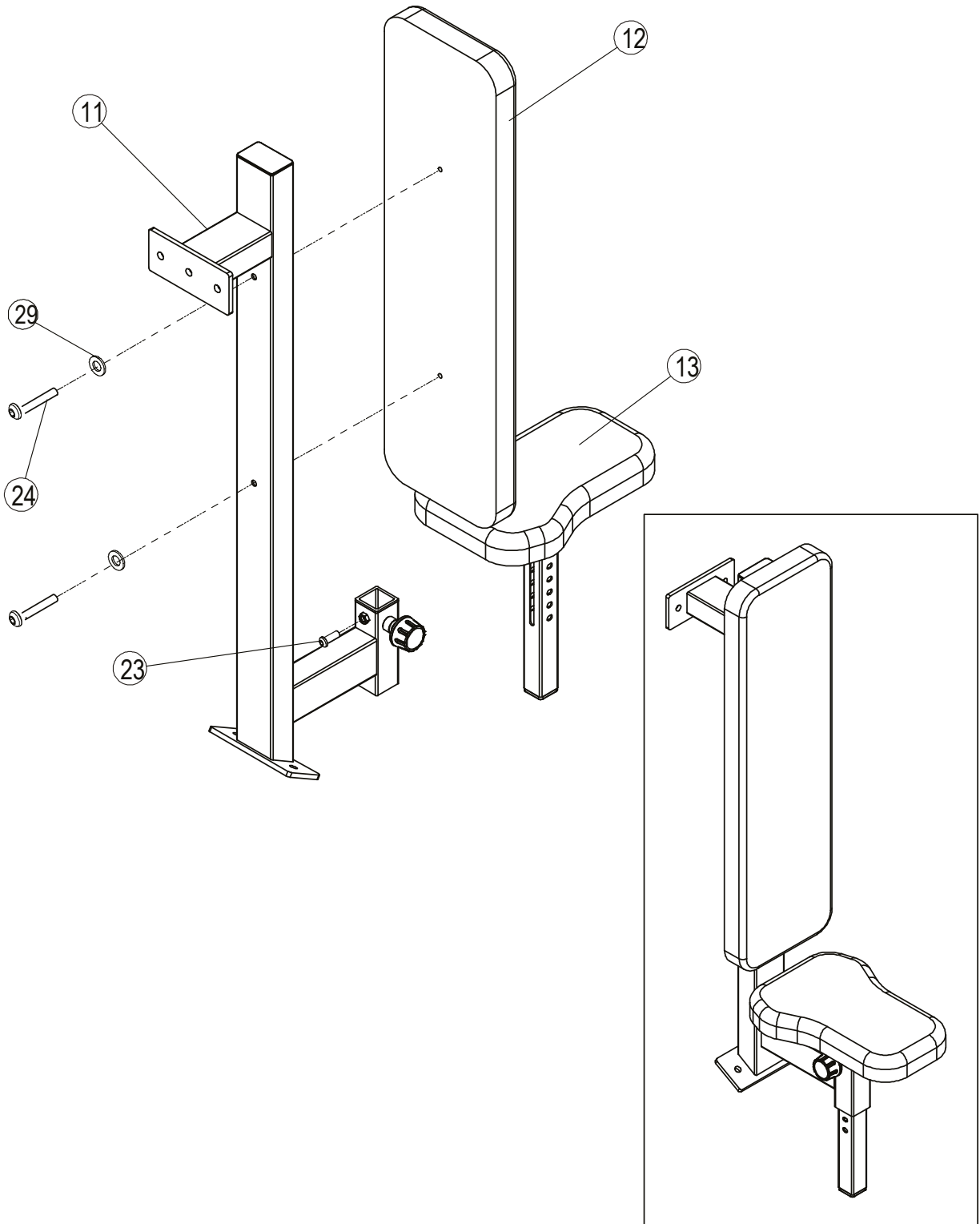
Step NO.	Item NO.	Name	Quantity	Item NO.	Name	Quantity
3	No.7	Rotating arm right	1	No.17	Bearing cover	2
	No.8	Rotating arm left	1	No.22	M10*20 Allen inner hex blot	2
	No.19	Limit collar	2	No.30	M10 Flat washer *2	2



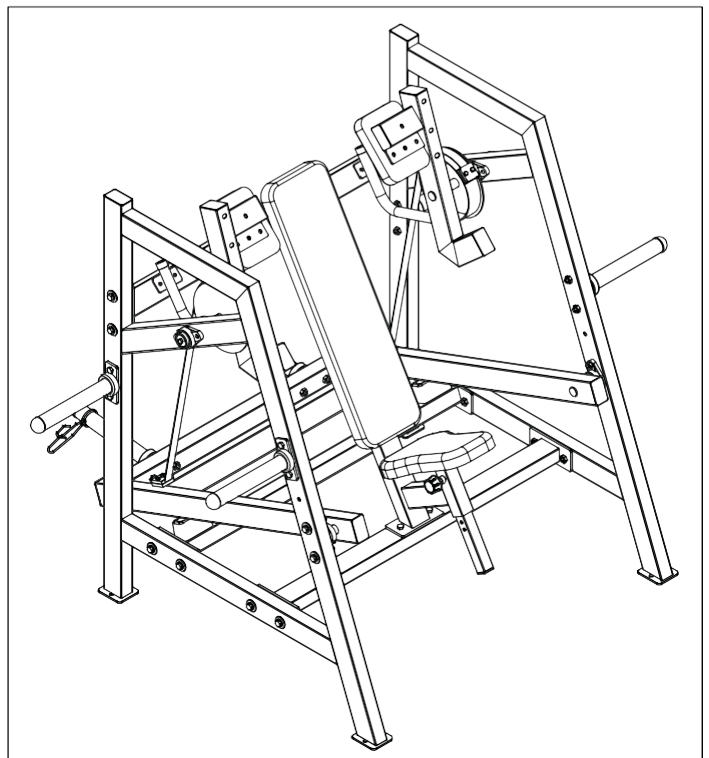
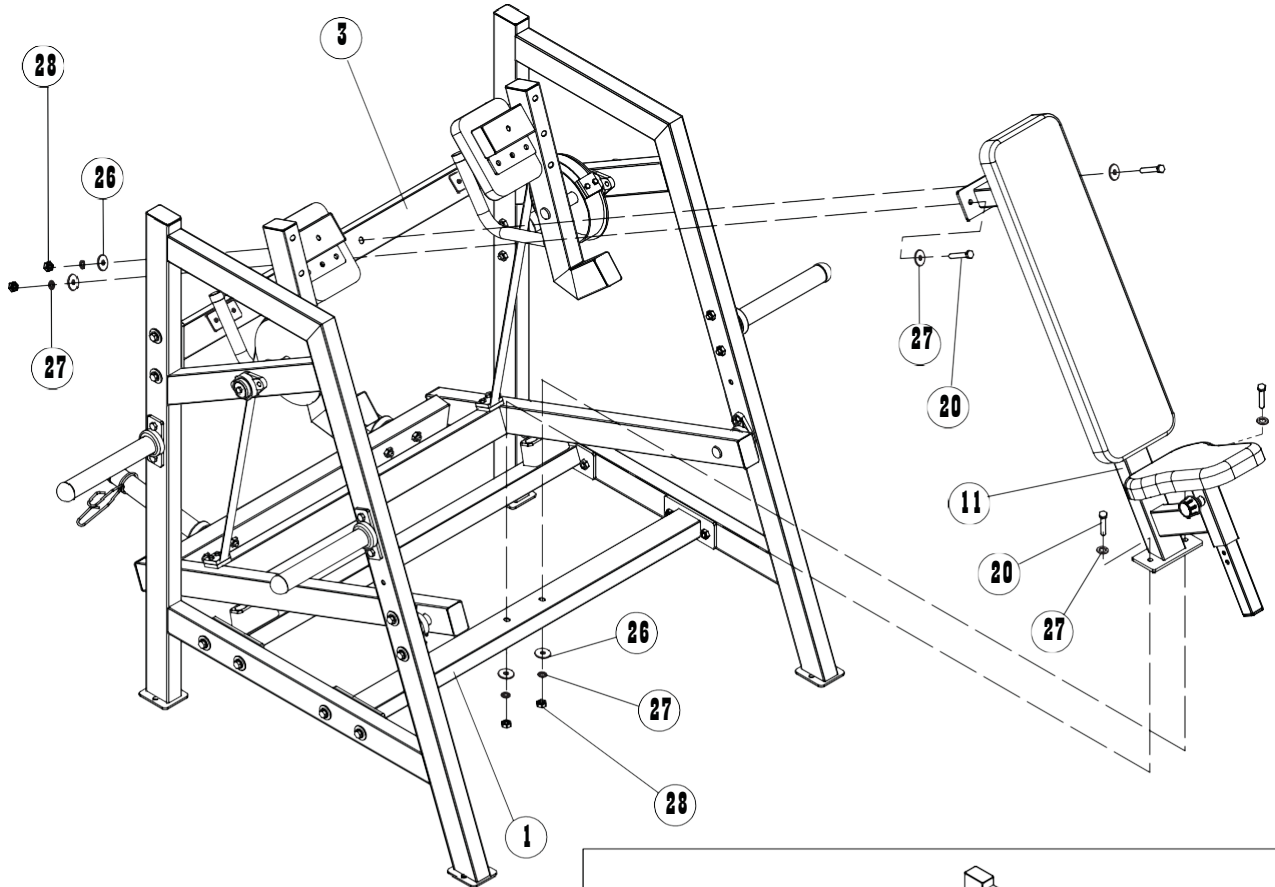
Step NO.	Item NO.	Name	Quantity	Item NO.	Name	Quantity
4	No.9	Belt fixing plate	4	No.23	M8*20 Allen inner hex blot	8
	No.10	Gravity belt	2	No.29	M8 Flat washer	8



Step NO.	Item NO.	Name	Quantity	Item NO.	Name	Quantity
5	No.11	Pad fixing bracket	1	No.24	M8*70 Allen inner blot	2
	No.12	Back pad	1	No.23	M8*20 Allen inner hex blot	1
	No.13	seat pad	1	No.29	M8 Flat washer	2



Step NO.	Item NO.	Name	Quantity	Item NO.	Name	Quantity
6	No.20	M12*75 Hex blot	4	No.27	M12 Flat washer	8
	No.26	M12 Nylon washer	4	No.28	M12 Nylon nut	4



Step NO.	Item NO.	Name	Quantity	Item NO.	Name	Quantity
7	No.14	Arm support	1	No.27	M12 Flat washer	8
	No.25	M12*100 Hex blot	4	No.28	M12 Nylon nut	4
	No.26	M12 Nylon washer	4			

